

Mini Vibrating Fork Level Switch - MVFSL

It is a compact and easy to install switch suitable for detection of wide variety of liquids in tanks containers tanks containers or pipelines.

Salient Features

- Compact and lightweight design
- Rugged SS housing
- Minimal maintenance as vibration has self-cleaning property
- Unaffected by bubbles, foam or vibration
- Service-friendly plug connection

Construction & Operation

Vibrating fork is attached to a housing containing piezo crystal and sensing electronics. Fork vibrates in air at resonant frequency of piezo crystal. The vibration gets damped when fork comes in contact with liquid, which is sensed by the electronics to provide PNP switching output. This output can be used to operate relay or as input to PLC.

Specifications

Terminal	: DIN connector
Mounting	: Top or Side mounted
Process Connection	: ½" BSP (M)
Housing	: SS304
Fork MOC	: SS316
Insertion Length	: Standard – 68 mm
Resonant frequency	: 1.8 KHz
Supply	: 24 VDC ±10%
Output	: PNP (20 mA max, NO Type)
Power Consumption	: 0.5W
Switching Indication	: Red LED; OFF – Normal, ON- Alarm
Max Viscosity	: < 10000 CPS
Ambient Temp	: 0 to 55 °C
Max Temperature	: 70 °C
Max Pressure	: 10 kg/cm ² – Standard High pressure on demand upto 40 kg/cm ²

Techtrol Switch Amplifier – TSA (Optional)

Input	: 1 no. x PNP or NPN O/P from switch
Power Supply	: 90 to 270 VAC, 24 VDC ±10%
Relay Output	: 1 x SPDT or DPDT, 5A, 250 VAC
Enclosure	: ABS x IP41, panel mounted; Size: 72 x 72 x 120 mm D

Refer TSA Catalogue for detail specifications



Dimensional Drawing

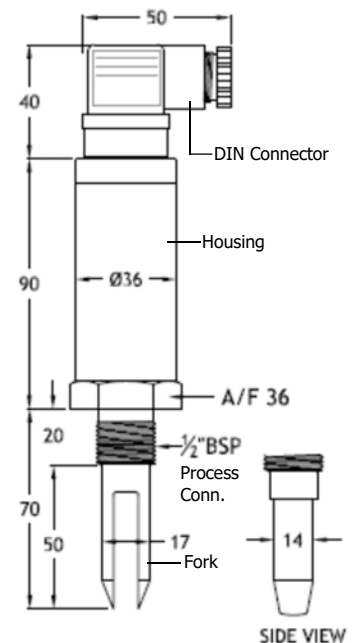

Terminations

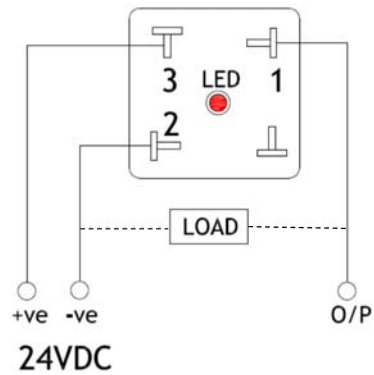

Installation

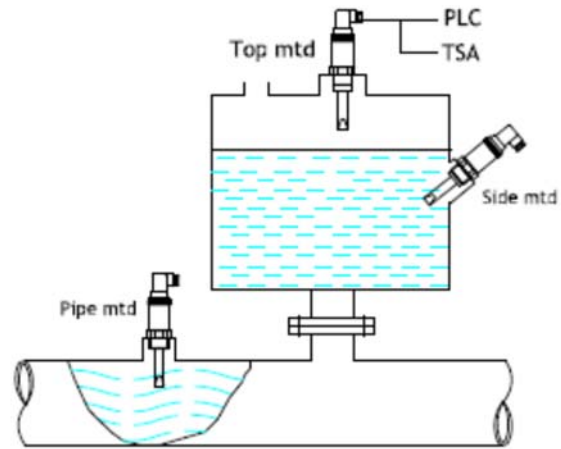

Applications

1. Flow / no flow of liquid in pipeline
2. Overfill detection
3. Leak detection
4. High, low level alarm
5. Pump dry run protection & pump control
6. Oil, water and similar liquids

Model Identification

	MVFSL -	
Process Connection		
½" BSP (M)		B
Others		O